

## Product Introduction

### Product Design Feature

- This series of products can be widely used in enclosed area for climate control, such as wireless communication cabinet, battery cabinet, industry control cabinet etc;

### Product Design Feature

- Remote measure, remote communication, remote control, which can realize multiple automatic protection and comprehensive self-testing function;
- Strict process control and international brand parts deployed to ensure high quality and reliable of this product;
- Multiple self protection design & Interchangeable monitoring software interface. RS485 communication(MODBUS protocol);
- Circulation fans stepless speed regulation function;
- LED Display, all the settings can changed at the field;
- The heating function is optional
- Dry contact alarm output, NO/NC optional;

## Technical Parameters

Name	DC Cabinet Heat-Exchanger	
Code	11680	
Model	HRUC E 150/N/E/D	HRUC E 150/N/E/D/H0B0
Mounting Method	Semi-embedded Mounting	
Power Supply DC	-48V±20%	
Rated current DC	4.4A	
Start-up current DC	5.3A	
Cooling Capacity	150W/K	
Fans Power Consumption	190W	
Fans	2* R1G225	
Internal Airflow	860m <sup>3</sup> /h	
Rated voltage AC	NA	220VAC±20%
Frequency AC	NA	50~60±3Hz
Rated current AC	NA	3.6A
Heater Power	NA	800W
Working Temperature Range	-40°C~+65°C	
Noise Level	55dB ~ 60dB(A)	
IP Grade	IP55	
Net Weight	45kg	
Dimensions	1250*522*240 (mm,HxWxD)	
CE&RoHS Compliant	YES	
Surface Treatment	Outdoor type powder coating standard color: RAL7035	

Int.Fan Speedvs.Cabinetinside temperature Curve

Ext. Fan Speed vs.Cabinetinside temperature Curve

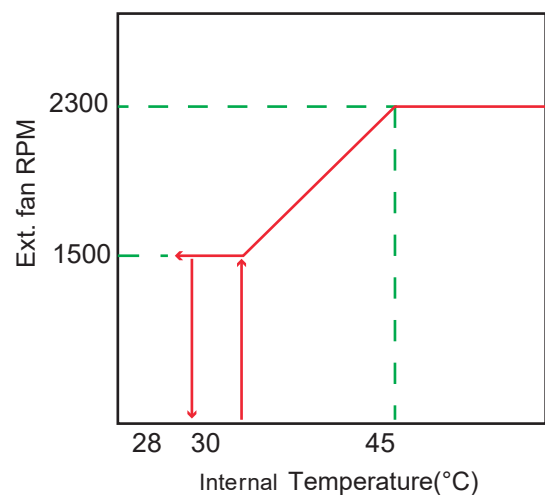
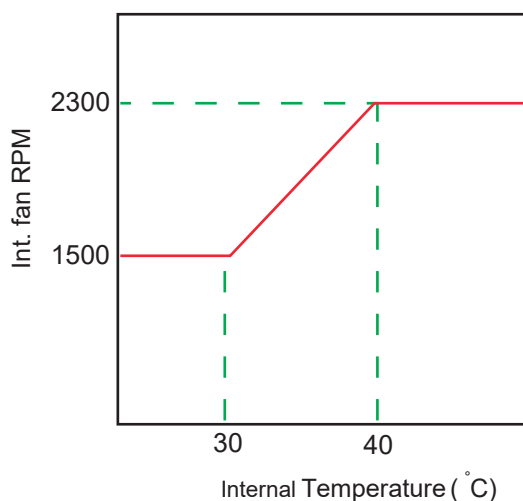

## Product Dimensions

11680	Model	Installation
	HRUC E 150/N/E/D	Semi-embedded Mounting
	HRUC E 150/N/E/D/H080	

### Product Dimensions

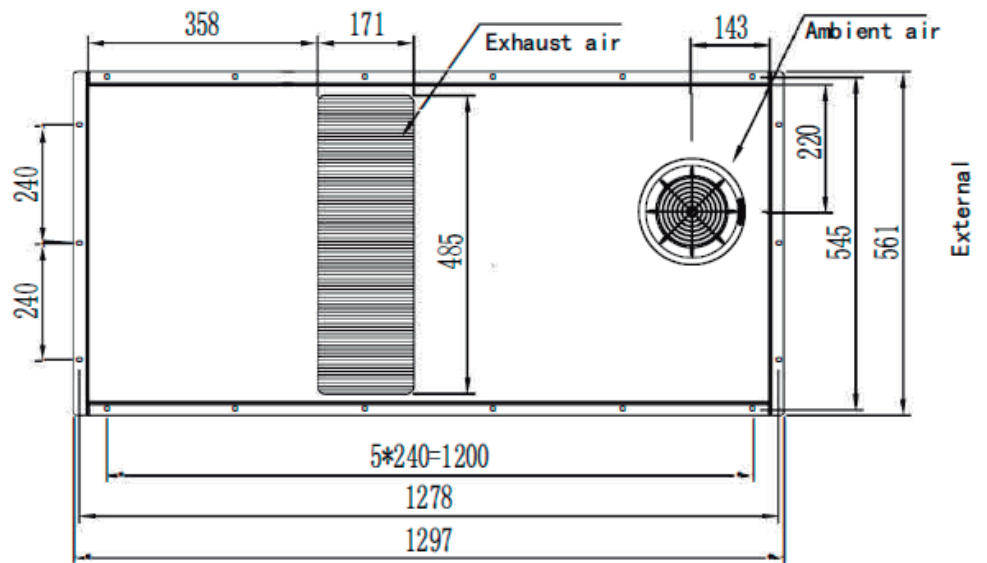
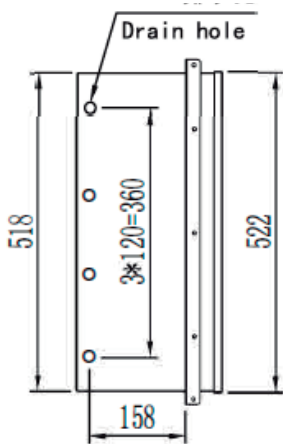
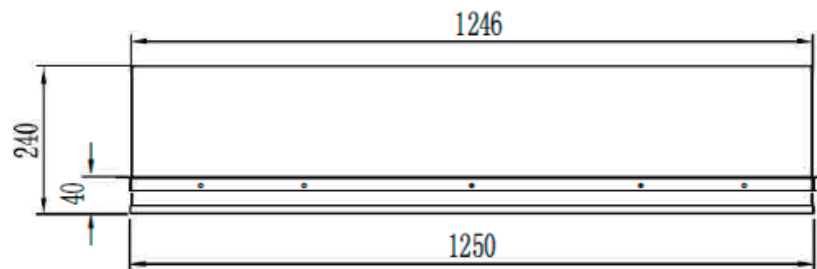
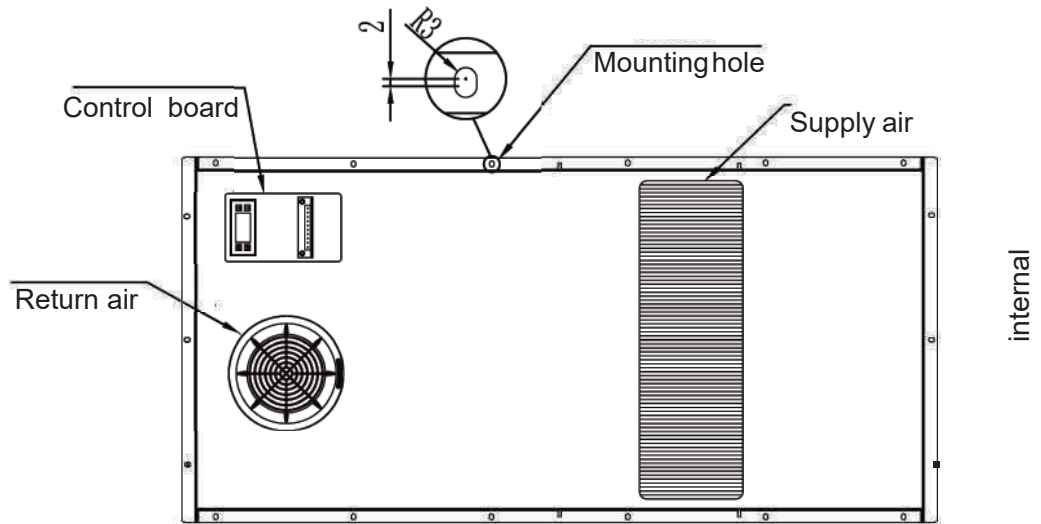

## Installation Dimensions

Code	Model	Installation
11680	HRUC E 150/N/E/D	Semi-embedded Mounting
	HRUC E 150/N/E/D/H100	

## Cabinet's Door Cutting Dimensions

Figure 1-Cabinet Door Cutting Dimension

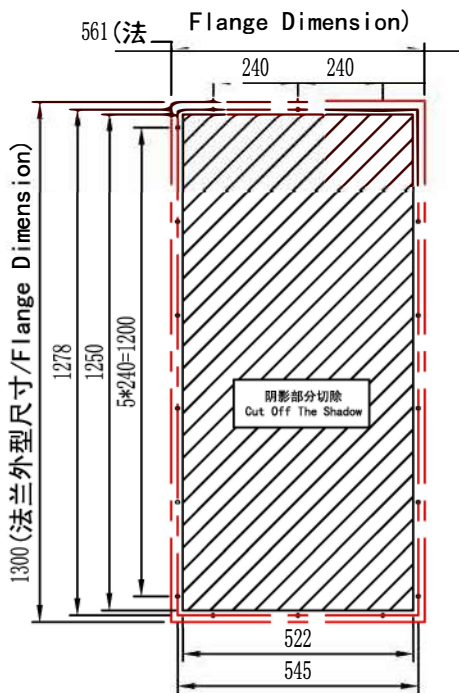

Figure 2-Air open design of cowling

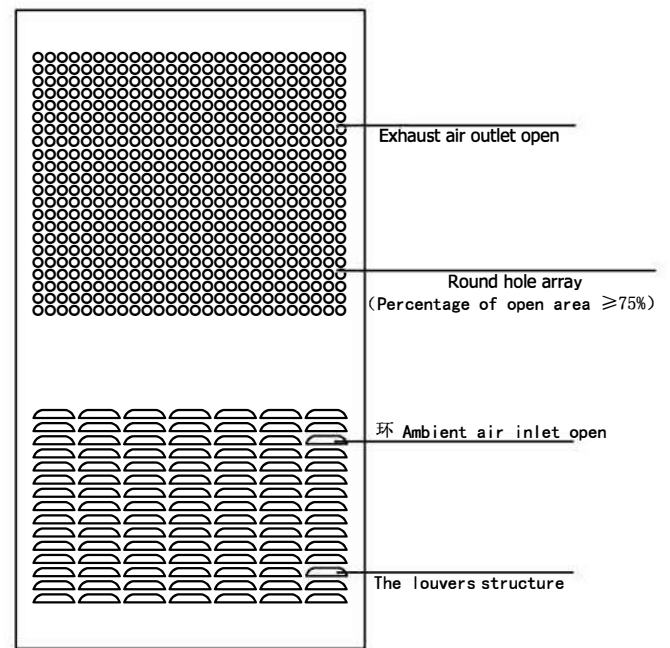
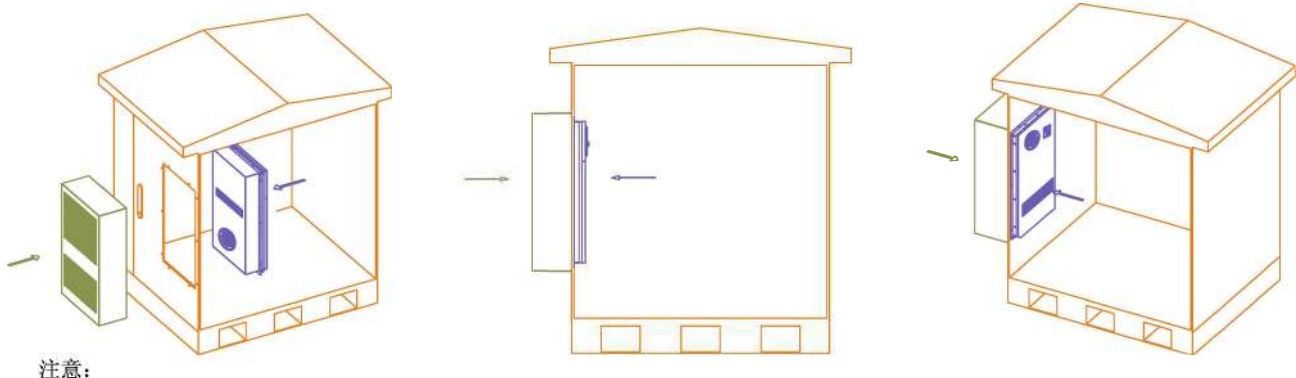

Figure 3-Installation Instruction



### Attention:

This series Heat exchanger does not need a cowling, if customer does want to put a cowling outside unit, please follow below rules:

1. The cowling can be made by customer self, the design of cowling please refer to figure 2

2. The inlet and outlet open for ambient air in and exhaust air out should be big enough to ensure enough air volume circulation.

This is very important to the Heat exchanger capacity and less service.

3. When you make a cowling design/installation, make sure the inlet air and outlet air not been short cut, this is also critical to keep unit have best cooling performance.

## Terminal instructions

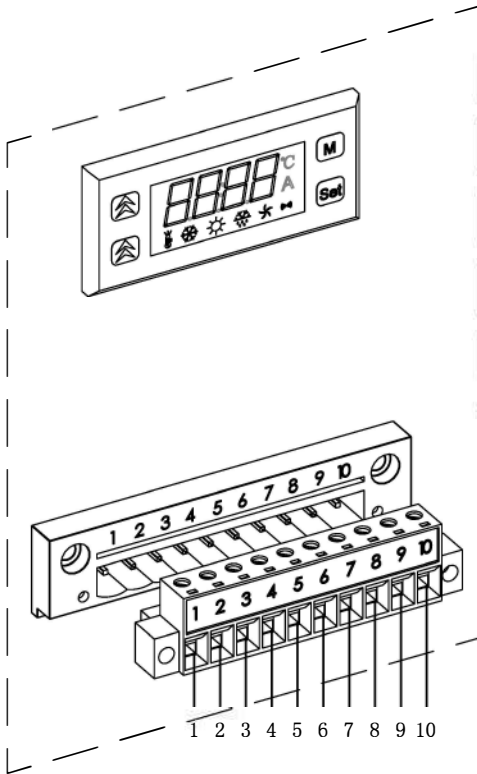

Instructions of display panel:

The display panel shows cabinet temperature under normal circumstance and shows alarm code when there is a mal function.

In the bottom is the status bar, different lamp represents different status.

Lamp on when setting mode; Flashing when self diagonse.

Lamp on when heating exchanger.

Lamp on when heating; Flashing when heater alarm.

Lamp on when external fan is running; flashing when ext. fan.

Flashing when alarm.

No.	Symble	Definition	Description
1	OV	Positive electrode of DC power	/
2	-48V	Negative electrode of DC power	/
3	PE	Ground wire of power	/
4	N	Neutral line of AC power	Use with heater
5	L	Live line of AC power	Use with heater
6	NO	Dry contact alarm output-NO	/
7	COM	Dry contact alarm output-COM	/
8	NC	Dry contact alarm output-NC	/
9	RS485 +	Communication interface	/
10	RS485 -	Communication interface	

